

SGI[®] InfiniteStorage[™] 120

Mass Storage Hardware Topics

Edition -001

007-4853-001



Proprietary Rights Notices

COPYRIGHT

© 2006, Silicon Graphics, Inc. All rights reserved; provided portions may be copyright in third parties, as indicated elsewhere herein. No permission is granted to copy, distribute, or create derivative works from the contents of this electronic documentation in any manner, in whole or in part, without the prior written permission of Silicon Graphics, Inc.

LIMITED RIGHTS LEGEND

Use, duplication, or disclosure by the Government is subject to restrictions as set forth in the Rights in Data clause at FAR 52.227-14 and/or in similar or successor clauses in the FAR, or in the DOD, DOE or NASA FAR Supplements. Unpublished rights reserved under the Copyright Laws of the United States. Contractor/manufacturer is Silicon Graphics, Inc., 1500 Crittenden Lane, Mountain View, CA 94043.

TRADEMARKS AND ATTRIBUTIONS

Silicon Graphics, SGI, and the SGI logo are registered trademarks, and InfiniteStorage is a trademark, of Silicon Graphics, Inc., in the United States and/or other countries worldwide.

Linux is a registered trademark of Linus Torvalds. All other trademarks mentioned herein are the property of their respective owners.

Document Description

007-4853-001

This document will remain the official reference source for all revisions and releases of this product until rescinded by an update.

Disclaimer

It is the policy of Silicon Graphics Inc. to improve products as new technology, components, software, and firmware become available. SGI reserves the right to make changes to any products herein at any time without notice. All features, functions, and operations described herein may not be marketed in all parts of the world.

Contents

Drive Module Description.....	2
Components Accessed From the Front of the Module	2
Components Accessed From the Rear of the Module.....	2
Drive Module Specifications.....	3
Drive Module Status LEDs	3
Environmental Specifications	5
ESM Canisters.....	7
Redundancy.....	7
Connections.....	7
ESM Lights	8
Environmental Services Monitor Performance Specifications	10
Power-Fan Canisters	11
Redundancy.....	11
Power-Fan Canister Lights.....	12
Disk Drives.....	13
Disk Drive Lights.....	14
Hot Swap	16
Drive Module Replacement Parts	17
Tools and Equipment	18
Turning On the Power to the Drive Module	19
Turning Off the Power to the Drive Module.....	20
Installing SAS Cables.....	22
Removing the Components from the Drive Module.....	23
Reinstalling the Components in the Drive Module.....	26
Replacing a Failed Environmental Services Monitor	28
Replacing a Failed Power-Fan Canister	31
Replacing a Failed Disk Drive	34

List of Figures

Figure 1. SGI InfiniteStorage 120 Drive Module	1
Figure 2. Drive Module – Front View	2
Figure 3. Drive Module – Rear View	2
Figure 4. Drive Module Status LED Locations	4
Figure 5. Service for the ESM Canister is from the Rear of the Drive Module	7
Figure 6. SAS Pinouts on SGI Host System I/O Port	8
Figure 7. SAS Connectors on an ESM	8
Figure 8. ESM Lights	8
Figure 9. Service for the Power-Fan Canister is from the Rear of the Drive Module	11
Figure 10. Power-Fan Canister Lights	12
Figure 11. Service for the Disk Drive is from the Front of the Module	13
Figure 12. Disk Drive Numbering	13
Figure 13. Disk Drive Lights	14
Figure 14. Power Switches on a Drive Module	19
Figure 15. Drive Active Light Must be Turned Off Before Turning Off the Power	20
Figure 16. Power Switches on a Drive Module	21
Figure 17. SAS Cabling Example	22
Figure 18. Removing a Disk Drive	24
Figure 19. Removing a Power-Fan Canister	24
Figure 20. Removing an ESM	25
Figure 21. Reinstalling a Disk Drive	26
Figure 22. Reinstalling a Power-Fan Canister	27
Figure 23. Replacing an ESM	27
Figure 24. ESM Fault Light	28
Figure 25. Removing an ESM	29
Figure 26. ESM Lights	29
Figure 27. Fault Light and Power Switch on a Power-Fan Canister	31
Figure 28. Power Switches on a Drive Module	31
Figure 29. Removing a Power-Fan Canister	32

Figure 30. Power Light and Fault Light on a Power-Fan Canister	32
Figure 31. Removing a Disk Drive	35

List of Tables

Table 1. Specifications for the Drive Module	3
Table 2. Temperature and Humidity	5
Table 3. Altitude	5
Table 4. Shock and Vibration	5
Table 5. ESM Lights	9
Table 6. Performance Specifications for the ESMs	10
Table 7. Power-Fan Canister Lights	12
Table 8. Disk Drive Ports	14
Table 9. Disk Drive Lights	15
Table 10. Disk Drive State Represented by Lights	15

InfiniteStorage 120 Hardware Topics

This document is a collection of hardware topics that describe the SGI InfiniteStorage 120 drive module.

Figure 1 SGI InfiniteStorage 120 Drive Module



This document provides:

- Descriptions of the drive module
- Drive module specifications
- Descriptions of the environmental services monitor (ESM) canister
- Descriptions of the power-fan canister
- Descriptions of the disk drives
- Procedures related to drive module maintenance

Drive Module Description

A drive module provides storage capacity. The environmental services monitors (ESMs) in the drive module connect to a host. A drive module contains disk drives, ESMs, fans, and power supplies.

Figure 2 shows the front of the drive module, and Figure 3 shows the rear of the drive module. The figures show the following components:

Components Accessed From the Front of the Module

- **Bezel** – A plastic-molded frame
- **Drives** – Twelve removable disk drives

Components Accessed From the Rear of the Module

- **ESM canisters** – Two removable canisters that contain the ESMs
- **Power-fan canisters** – Two removable canisters that contain the power supplies and cooling fans

Figure 2 Drive Module – Front View

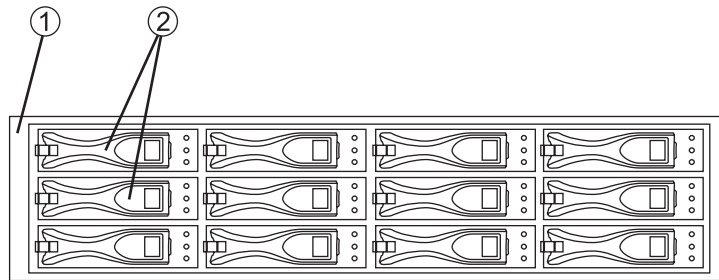

78015-01

1. Bezel
2. Disk Drives

Figure 3 Drive Module – Rear View

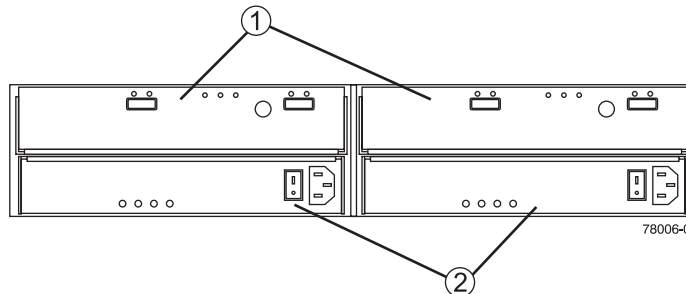

78006-03

1. ESM Canisters
2. Power-Fan Canisters

Drive Module Specifications

The following table lists the physical and electrical specifications for the drive module.

Table 1 Specifications for the Drive Module

Item	Specification
Dimension	Height: 8.8 cm (3.5 in.) with rails (2U); width: 44.7 cm (17.6 in.); depth: 51.4 cm (20.3 in.)
Weight	Empty: 14 kg (32 lb); fully loaded: 24.6 kg (54.3 lb)
Input voltage	100–240 V
Input frequency	50 or 60 Hz (nominal)
Steady-state maximum current	At 240 V: 1.9 A; at 100 V: 3.9 A
Standby current	0.21 A at 240 V, 60 Hz; 0.15 A at 100 V, 50 Hz

Drive Module Status LEDs

Each drive module is equipped with four enclosure summary LEDs. These are stacked internally on the far-left side of the enclosure and are visible at the front of the unit (see [Figure 4 on page 4](#)).

The LEDs (top to bottom) have the following color and functional descriptions:

- Amber - when lit, this LED indicates that a component within the module has failed.
- Amber - when lit, environmental temperatures have exceeded functional tolerances.
- White - this LED is reserved for future functional uses.
- Green - shows that +5V power to the module is on.

Figure 4 Drive Module Status LED Locations

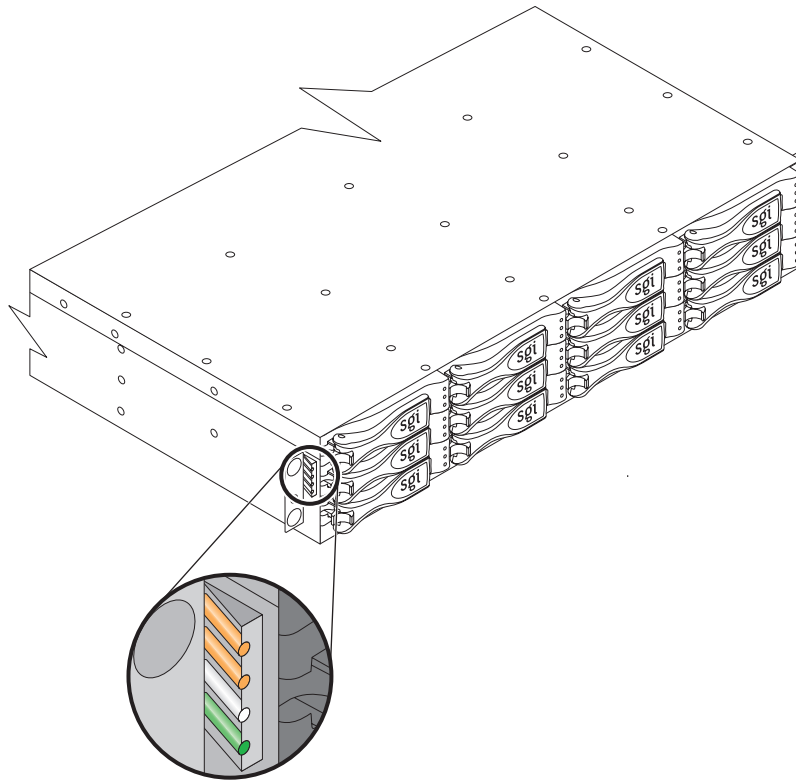

Environmental Specifications

The following tables list the temperature, humidity, altitude, shock, and vibration specifications for the drive module.

Table 2 Temperature and Humidity

Condition	Parameter	Specification
Temperature ¹	Operating range	10°C to 40°C (50°F to 104°F)
	Maximum rate of change	10°C (18°F) per hour
	Storage range	-10°C to 65°C (14°F to 149°F)
	Maximum rate of change	15°C (27°F) per hour
	Transit change	-40°C to 65°C (-40°F to 149°F)
	Maximum rate of change	20°C (36°F) per hour
Relative humidity (noncondensing)	Operating range	20% to 80% (noncondensing)
	Storage range	10% to 90%
	Transit range	5% to 95%
	Maximum dew point	26°C (79°F)
	Maximum gradient	10% per hour

¹ If you plan to operate a system at an altitude between 1000 m to 3000 m (3280 ft to 9842 ft) above sea level, lower the environmental temperature 1.7°C (3.3°F) for every 1000 m (3280 ft) above sea level.

Table 3 Altitude

Environment	Specification
Operating	30.5 m (100 ft) below sea level to 3000 m (9842 ft) above sea level
Storage	30.5 m (100 ft) below sea level to 3000 m (9842 ft) above sea level
Transit	30.5 m (100 ft) below sea level to 12,000 m (40,000 ft) above sea level

Table 4 Shock and Vibration

Condition	Parameter	Specification
Vibration	Operating	5-500-5 Hz, 0.25 g sinusoidal, 2 octave per minute, 3 axis
	Nonoperating (unpacked)	5-500-5 Hz, 1.0 g sinusoidal, 2 octave per minute, 3 axis
	Transit and storage (packed)	5-500-5 Hz, 2.0 g sinusoidal, 2 octave per minute, 3 axis

Condition	Parameter	Specification
Shock	Operating (no damage)	5-g peak acceleration, 11 ms duration, 1/2 sine pulse, 3 axis
	Nonoperating (unpacked)	25-g peak acceleration, 11 ms duration, 1/2 sine pulse, 3 axis
	Transit and storage (packed)	30-g peak acceleration, 11 ms duration, 1/2 sine pulse, 3 axis

ESM Canisters

An environmental services monitor (ESM) provides the interface between the disk drives in a drive module and the hosts. The hosts connect directly to the ESMs. Each drive module contains two ESM canisters.

Figure 5 shows an ESM canister that is being inserted into the rear of a drive module.

Figure 5 Service for the ESM Canister is from the Rear of the Drive Module

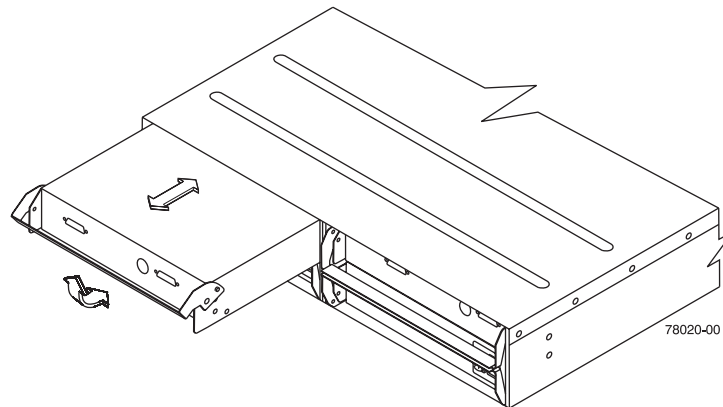

Redundancy

When a drive module contains two ESMs, if one ESM fails, the other ESM will provide a data path to the disk drives. You can replace a failed redundant ESM while the power to the drive module is turned on and the drive module is processing data.

Connections

The ESM attaches to the host using SAS cables. The ESM has two SAS connectors.

- **SAS-in** – Used for cables from the host to the ESM.
- **SAS-out** – Not used.

Figure 6 shows the SAS pinout connections on the SGI host system's standard I/O port.

Figure 6 SAS Pinouts on SGI Host System I/O Port

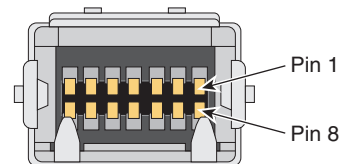
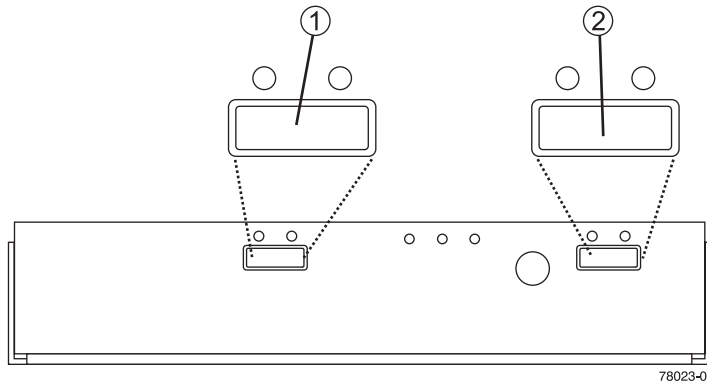

Figure 7 shows the SAS connectors on an ESM.

Figure 7 SAS Connectors on an ESM



1. SAS-In Connector
2. SAS-Out Connector

ESM Lights

Figure 8 shows the ESM's lights.

Figure 8 ESM Lights

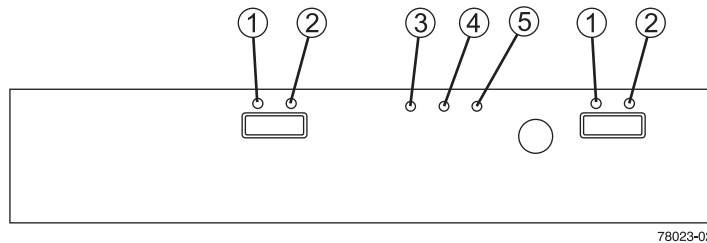

Table 5 describes the lighting patterns.

Table 5 ESM Lights

Location	Light	Color	On	Off
1 ^a	ESM Link Fault	Amber	A link error occurred.	No errors have occurred.
2	ESM Link	Green	The link is active.	A link error occurred.
3	Service Indicator	Blue	This light is not used; however, it blinks during power-on initialization.	
4	Fault	Amber	A fault exists within the ESM.	Normal condition.
5	Power	Green	Power is present.	No power is applied.

a. The amber LED also comes on when connecting cable HSSDC2 to MiniSAS (2 lanes to 4 lanes).

Environmental Services Monitor Performance Specifications

The following table lists important performance specifications for each ESM in a drive module.

Table 6 Performance Specifications for the ESMs

Item	Specification
Data transfer to disk drive	3 Gb/s
Maximum number of disk drives	12 in each drive module

Power-Fan Canisters

The power-fan canister, with an integrated cooling fan, is a replaceable canister within a drive module.

Each drive module contains two power-fan canisters. The power-fan canister converts incoming AC power to DC power. The fan circulates air inside the module by pulling air in through the vents on the front of the canister and pushing air out of the vents on the back of each fan.

Figure 9 shows a power-fan canister that is being inserted into the rear of a drive module.

Figure 9 Service for the Power-Fan Canister is from the Rear of the Drive Module

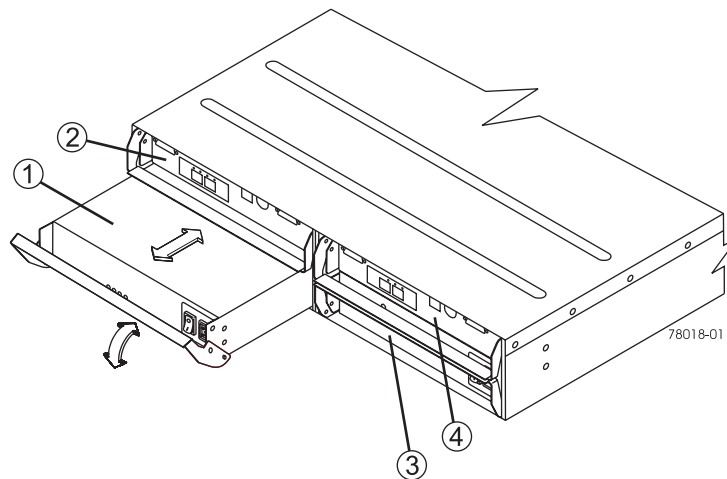

1. Power Supply A
2. ESM A
3. Power Supply B
4. ESM B

Redundancy

Because each drive module contains two power-fan canisters, if one power-fan canister is turned off or malfunctions, the other power-fan canister can maintain electrical power to the drive module.

Likewise, each power-fan canister contains two fans. The fans provide redundant cooling. If one of the fans in either power-fan canister fails, the remaining fans will continue to provide sufficient cooling to operate the drive module.

Each power-fan canister uses a 2-meter (6.56 ft.) power cord for connection to the rack's power distribution unit (PDU) or wall outlet.

Power-Fan Canister Lights

Figure 10 shows the power-fan canister's lights.

Figure 10 Power-Fan Canister Lights

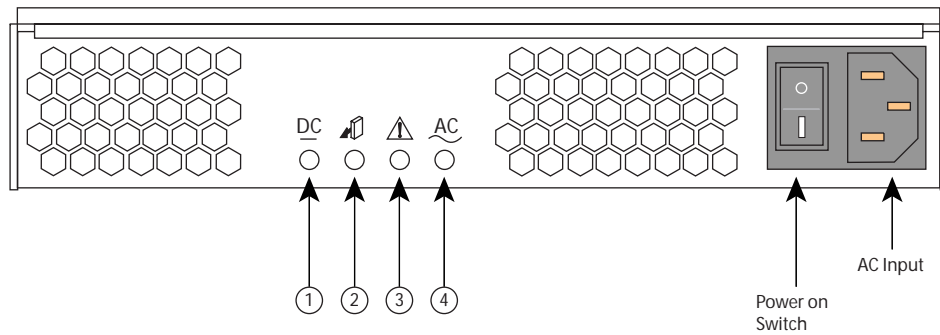

Table 7 describes the lighting patterns.

Table 7 Power-Fan Canister Lights

Location	Light	Color	On	Off
1	DC Power	Green	DC power from the power-fan canister is available.	DC power from the power-fan canister is not available.
2	Service Indicator	Blue	This light is not used; however, it blinks during power-on initialization.	
3	Fault	Amber	A fault exists within the power-fan canister.	Normal condition.
4	Power	Green	Power is present.	Power is not present.

Disk Drives

The disk drives store user data. A disk drive has three components: a hard drive, a hard drive carrier, and an adapter card for connecting the disk drive to the midplane. The disk drives are replaceable components.

Each drive module contains 12 disk drives. The disk drives are Serial Attached SCSI (SAS) disk drives.

Access to the disk drives is from the front of the drive module. [Figure 11](#) shows a disk drive that is being inserted into a drive module.

NOTE The disk drives in your module might differ in appearance from those shown here. The variation does not affect their function.

Figure 11 Service for the Disk Drive is from the Front of the Module

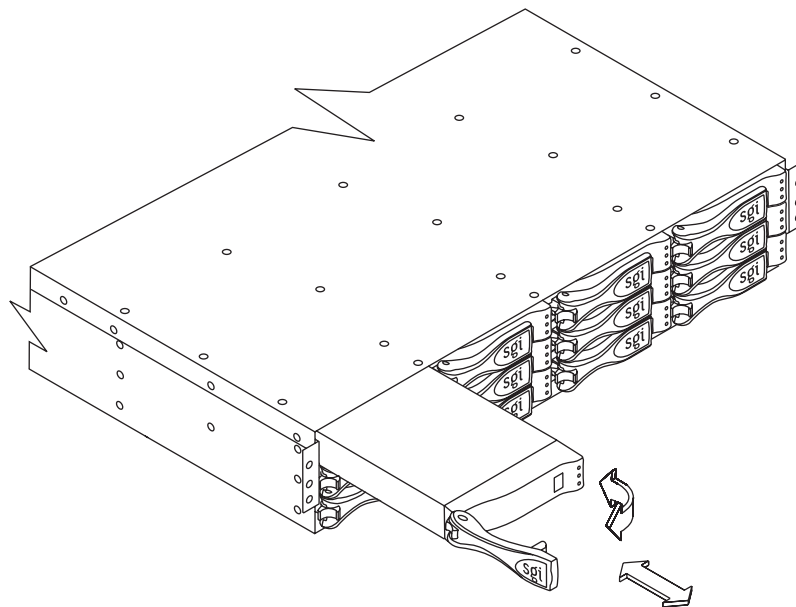

The physical locations of the disk drives are numbered 1 through 12, from left to right and top to bottom. [Figure 12](#) shows the disk drive numbering.

Figure 12 Disk Drive Numbering

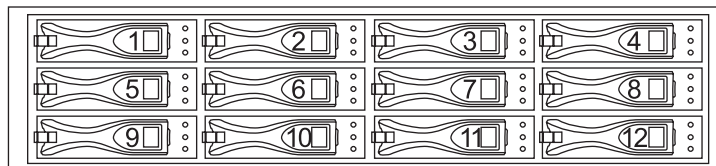

78015-02

Each disk drive has two ports. Each port has a separate number. Having two ports enables both ESMs to access a drive through the different port numbers. [Table 8](#) lists the disk drives and the port number each ESM uses for a disk drive.

Table 8 Disk Drive Ports

Disk Drive	ESM A	ESM B
1	P19	P14
2	P18	P10
3	P13	P9
4	P8	P8
5	P17	P18
6	P16	P13
7	P12	P12
8	P9	P11
9	P15	P19
10	P14	P17
11	P11	P16
12	P10	P15

Disk Drive Lights

Each disk drive has three lights. [Figure 13](#) shows the lights on a disk drive. [Table 9](#) lists what each light means.

Figure 13 Disk Drive Lights

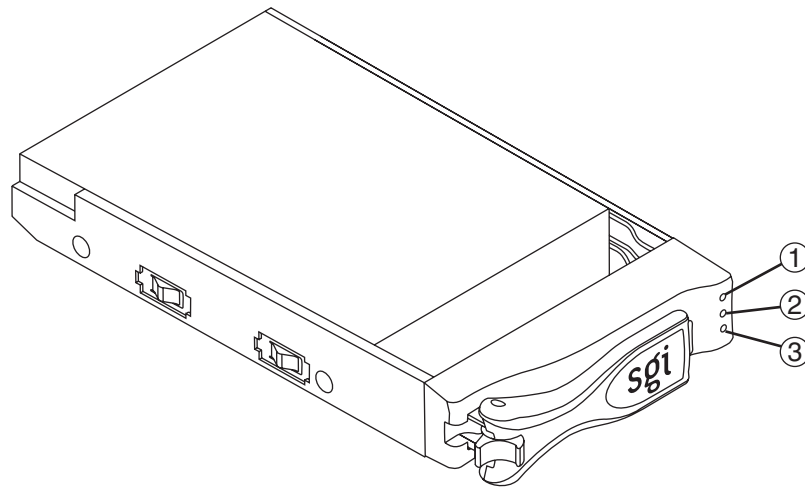

1. Not Used (reserved)
2. Disk Drive Fault Light (Amber)
3. Disk Drive Active Light (Green)

Table 9 Disk Drive Lights

Location	Light	Color	General Behavior
1			Not used (reserved).
2	Fault	Amber	The disk drive has a problem.
3	Power	Green	Off – The power is turned off.
			On – The power is turned on, and the drive module is operating normally.
			On blinking (0.5 s on, 0.5 s off) – Disk drive I/O activity is taking place.

Table 10 shows how to interpret the lights.

Table 10 Disk Drive State Represented by Lights

Disk Drive State	Activity (Green Light)	Fault (Amber Light)
Power is not applied.	Off	Off
Normal operation, power is turned on, no disk drive I/O activity is occurring.	On solid	Off
Normal operation, disk drive I/O activity is occurring.	On blinking	Off
Service action required, a fault condition exists, and the disk drive is offline.	On solid	Amber on solid

Hot Swap

The term *hot swap* refers to the ability to remove and replace a component in the drive module while the drive module is powered on.

NOTE The InfiniteStorage 120 is a JBOD module, you must halt all I/O transfers between the module and the host system(s) before you can perform any hot swap replacement of a disk drive.

Components that you can hot swap include the following:

- ESM canisters
- Power-fan canisters
- Disk drives

The following paragraphs briefly describe the difference between a drive module capable of hot swapping components and a drive module that does not have this capability.

In a drive module that has two ESMs and two power-fan canisters, these components are redundant, (note that the midplane circuit board is not). If one of these redundant components fails, you can replace it without turning off the power and without interrupting data processing.

In a drive module that has one ESM, you cannot replace the ESM without turning off the power to the drive module, which interrupts data processing. Similarly, in a drive module that uses a single power-fan canister, you cannot replace the power-fan canister without turning off the power to the drive module.

Drive Module Replacement Parts

This section lists replacement parts for the drive module.

To order parts, contact your Customer and Technical Support representative.

- Environmental services monitor (ESM)
- Disk drives
- Power-fan canister
- Host-to-ESM interface cables (SAS cables)

Tools and Equipment

This section lists the tools and equipment necessary to install and maintain the drive module.

- A cart or other surface to hold the module and its components
- No. 2 Phillips screwdriver
- Flat-blade screwdriver
- Antistatic protection, such as a grounded wrist strap
- Rackmount cabinet hardware mounting kits, including support rails and screws (if not already installed)
- Host-to-ESM interface cables (SAS cables)
- Tie wraps or other cable management devices (optional)

Turning On the Power to the Drive Module

Access the power switches from the rear of the drive module.

NOTE While power is being applied to the drive module, the lights on the front and the rear of the drive module intermittently come on and go off.

- 1 Make sure that all of the power cords are connected.

IMPORTANT If the power cords are not connected, make sure that both power switches on the power-fan canisters in the drive module are turned off before connecting the power cords or turning on the circuit breakers in the cabinet.

- 2 Turn on the main circuit breakers in the cabinet.
- 3 Turn on the power switch on both power-fan canisters in the drive module. [Figure 14](#) shows the location of the power switch on each power-fan canister in the drive module.

Figure 14 Power Switches on a Drive Module

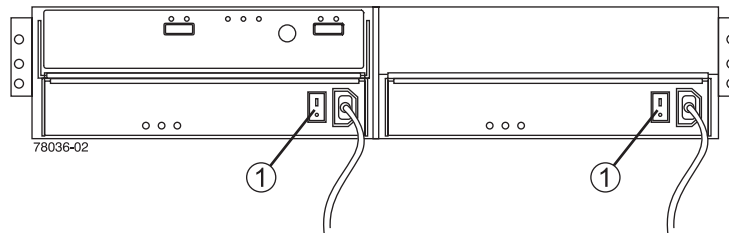

1. Power Switch

IMPORTANT The drive modules might take several minutes to turn on completely.

- 4 Determine the status of the drive module by checking all of the lights on the bezel, disk drives, power-fan canisters, and ESMs in the drive module. Make sure that all of the lights show normal operation.

Turning Off the Power to the Drive Module

Follow the steps in this procedure to make sure that you correctly turn off the power to the drive module. Access the power switches from the rear of the drive module.

IMPORTANT Turning off and turning on the power without waiting for the disk drives to spin down can damage them. Always let at least 30 seconds elapse from when you turn off the power until you turn on the power again.

- 1 Stop all input/output (I/O) activity to the drive module.
- 2 Determine the status of all of the drive module by checking all of the lights on the bezel, disk drives, power-fan canisters, and ESMs in the drive modules. Make sure that all of the lights show normal operation.

IMPORTANT Make sure that the Drive Active light on each disk drive is turned on, but not blinking. Look at the Drive Active lights from the front of the drive module. (Figure 15 shows the location of the Drive Active light on a disk drive.)

Figure 15 Drive Active Light Must be Turned Off Before Turning Off the Power

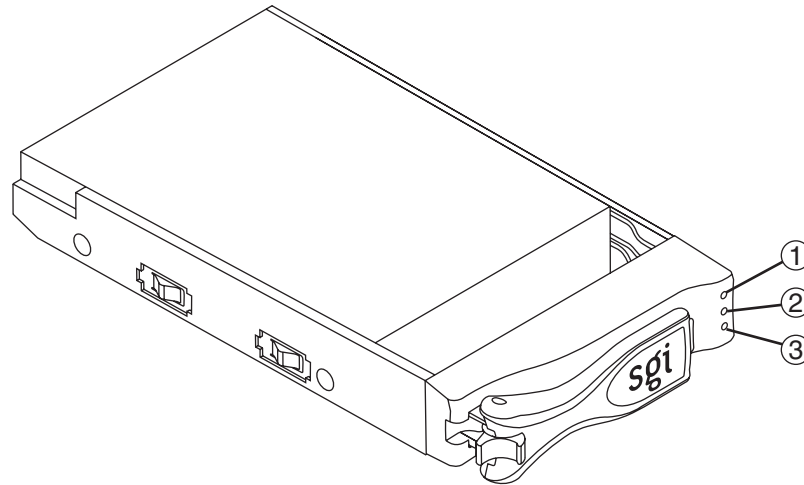

1. Not Used (reserved)
2. Disk Drive Fault Light (Amber)
3. Disk Drive Active Light (Green)

- 3 Turn off the power switch on both power-fan canisters in the drive module. [Figure 16](#) shows the location of the power switch on each power-fan canister in the drive module.

Figure 16 Power Switches on a Drive Module

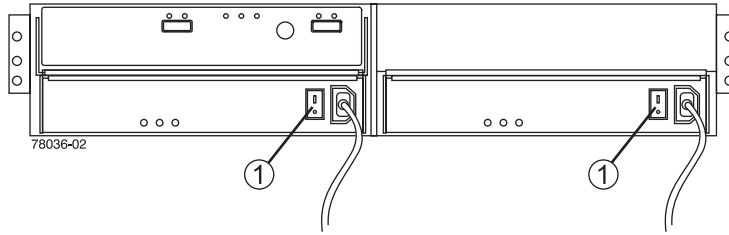

1. Power Switch

Installing SAS Cables

The cabling from the host to the ESMs in the drive module uses a “top-down” cabling scheme. In a top-down cabling scheme, the SAS cables connect from the host to the ESMs in the drive module closest to the host. In turn each additional ESM connects to another ESM in the next drive module. Different lengths of SAS cables are not required for top-down cabling. Note that you can connect the drive module to the standard SAS connection on the SGI host system. This may affect performance and data transfer rates, depending on the number of drives installed in the module.

Connect the SAS cables from the rear of the storage array. [Figure 17](#) shows an example of the SAS cables connected from a dual-SAS PCI card in the host to the ESMs in the drive module.

Figure 17 SAS Cabling Example

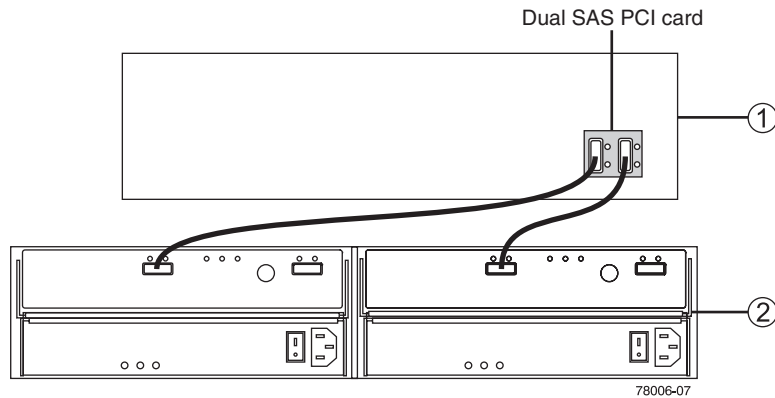

1. Host
2. Drive Module
 - 1 Insert the cable into the SAS connector on the ESM.
 - 2 Secure the SAS cable to the connector using the screws on the SAS cable.

Removing the Components from the Drive Module

Removing the components from the drive module makes the module lighter and easier to lift into the cabinet. Use the following procedure to remove the disk drives, power-fan canisters, and ESMS from the drive module. Place the components on a dry, level, static-free surface.

Before beginning this task, see “Tools and Equipment” on page 17 for a list of the tools that will be helpful in performing this procedure.



WARNING (W09) **Risk of bodily injury** –



>35 kg (70.5 lbs)

Three persons are required to safely lift the component.

A fully-populated drive module can weigh up to 40.8 kg (90 lb). Do not attempt to install the drive module in the cabinet unless you remove all of the components. The weight of the module with all of the components removed is approximately 15.9 kg (35 lb).

CAUTION **Possible hardware damage** – To prevent electrostatic discharge damage to the module, use proper antistatic protection when handling module components.

- 1** Put on antistatic protection.
- 2** Remove the disk drives from the drive module. [Figure 18](#) shows how to remove a disk drive.
 - a** Pull the drive handle to the left.
 - b** Use the handle to pull the disk drive out of the slot.
 - c** Put the disk drive on an antistatic, cushioned surface away from magnetic fields.
 - d** Repeat steps 2a through 2c to remove all remaining disk drives.
 - e** Although it is not required, you can also remove the blank drive components, if any exist.

Figure 18 Removing a Disk Drive

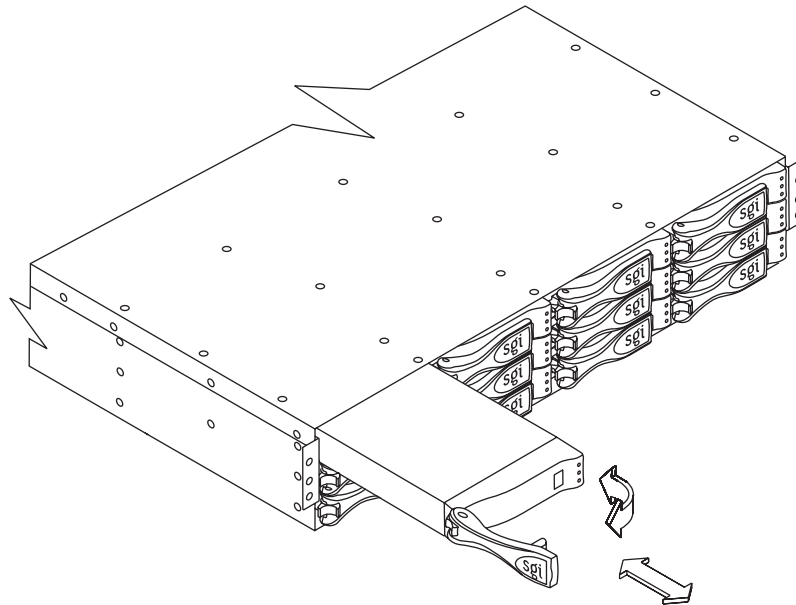

- 3** Remove the power-fan canisters from the drive module. [Figure 19](#) shows how to remove a power-fan canister.
 - a** Rotate the latch down to disengage the power-fan canister.
 - b** Use the latch as a handle to pull the power-fan canister out of the drive module.
 - c** Repeat steps 3a and 3b to remove the second power-fan canister.

Figure 19 Removing a Power-Fan Canister

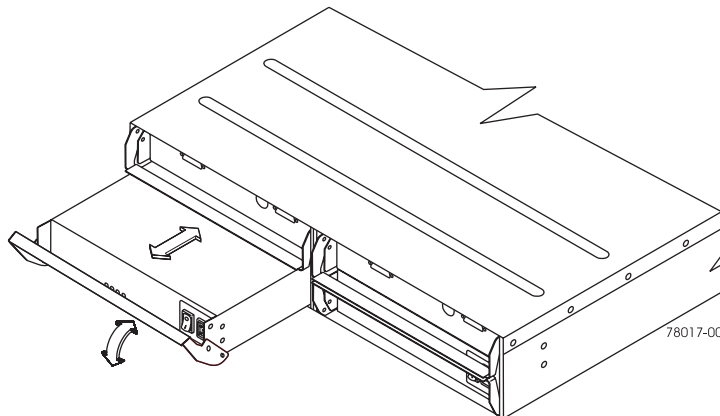

- 4** Remove the ESMs from the drive module. [Figure 20](#) shows how to remove an ESM.
 - a** Rotate the latch up to disengage the ESM canister.
 - b** Use the latch as a handle to pull the ESM canister out of the drive module.
 - c** Repeat steps 4a and 4b to remove the second ESM canister.

Figure 20 Removing an ESM

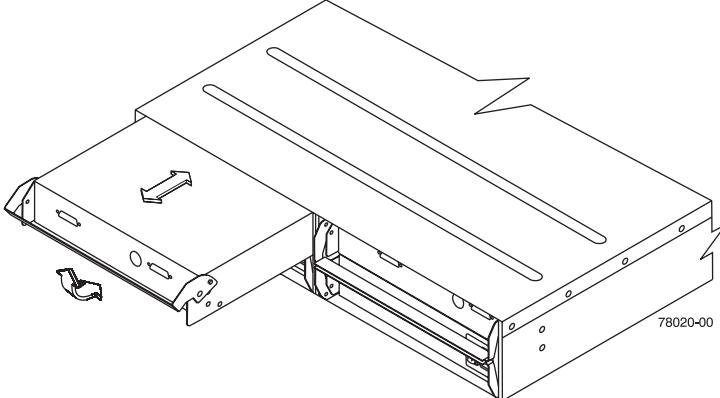

Reinstalling the Components in the Drive Module

If you have removed the components from the drive module, use this procedure to reinstall those components.

Before beginning this task, see “Tools and Equipment” on page 17 for a list of the tools that will be helpful in performing this procedure.

IMPORTANT If you previously removed operation disk drives and blank drives, you must reinstall the disk drives in the exact slots from which you removed them.

- 1 Reinstall the disk drives. [Figure 21](#) shows how to reinstall a disk drive.
 - a Beginning with the first drive slot on the lower-left side of the enclosure, place the disk drive on the slot guides, and slide the disk drive all the way into the slot.
 - b Push the drive handle to the left to lock the disk drive securely in place.
 - c Repeat steps 1a and 1b to reinstall all of the remaining disk drives and blank drives.

Figure 21 Reinstalling a Disk Drive

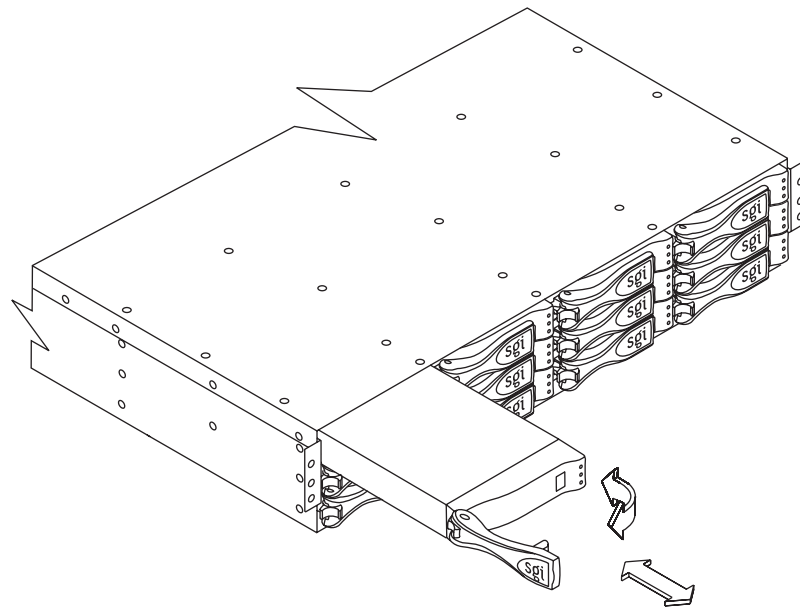

- 2 Reinstall the power-fan canisters. [Figure 22](#) shows how to reinstall a power-fan canister.
 - a Position a power-fan canister in front of either power-fan slot. Make sure that you have the power-fan canister positioned correctly.
 - b Slide the power-fan canister into the slot as far as it will go, and rotate the latch up to lock the power-fan canister into place.
 - c Repeat steps 2a and 2b to install the second power-fan canister.

Figure 22 Reinstalling a Power-Fan Canister

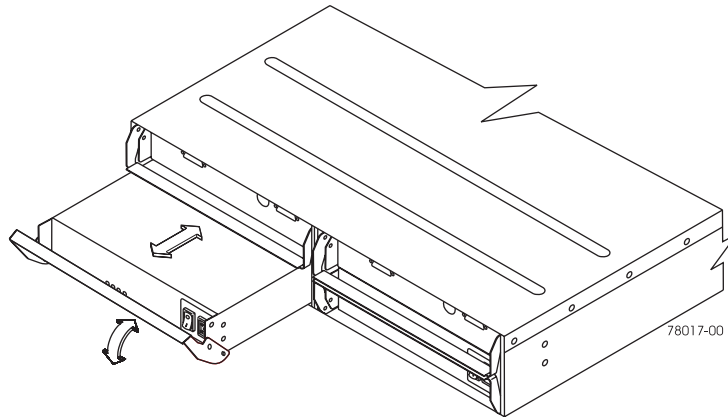

- 3** Reinstall the ESMs. [Figure 23](#) shows how to reinstall an ESM canister.
- a** Slide the first ESM canister into the empty slot as far as it will go, and rotate the latch down to secure the ESM canister into place.
 - b** Repeat step 3a to reinstall the second ESM canister.

Figure 23 Replacing an ESM

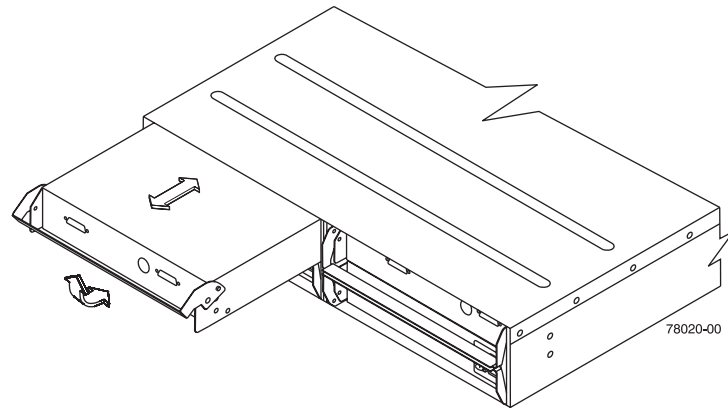

Replacing a Failed Environmental Services Monitor

This section describes how to replace a failed ESM.

Before you begin to replace an ESM canister in a drive module, gather antistatic protection and the replacement ESM canister.

CAUTION **Possible hardware damage** – To prevent electrostatic discharge damage to the module, use proper antistatic protection when handling module components.

- 1 Put on antistatic protection.
- 2 Unpack the new ESM.

Set the new ESM on a dry, level surface near the drive module. Save all packing materials in case you need to return the ESM.

- 3 Locate the failed ESM by checking the ESM Fault lights. If a fault is detected, the amber light is on. [Figure 24](#) shows the location of the ESM Fault light.

Figure 24 ESM Fault Light

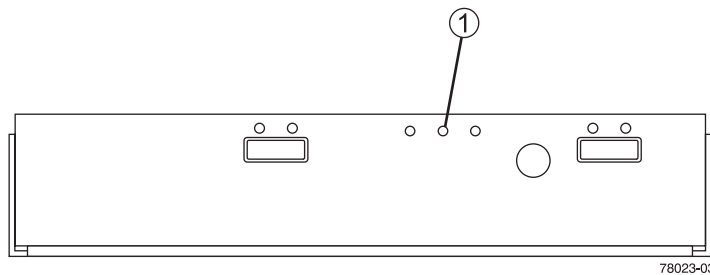

1. ESM Fault Light

- 4 Disconnect the SAS cable from the host.
- 5 Remove the failed ESM from the drive module. [Figure 25](#) shows how to remove an ESM.
 - a Rotate the latch up to disengage the ESM canister.
 - b Use the latch as a handle to pull the ESM canister out of the drive module.

Figure 25 Removing an ESM

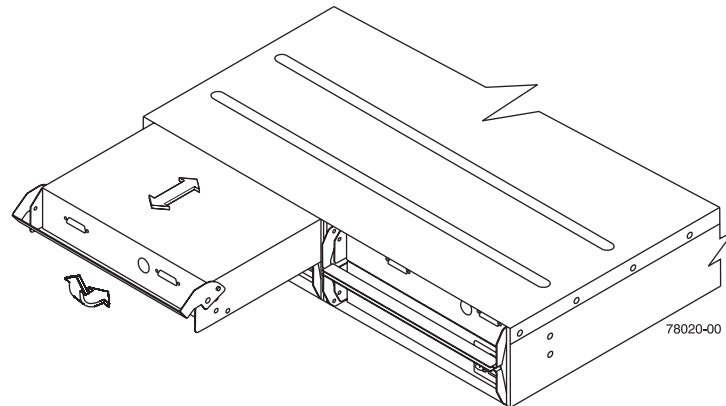

- 6 Slide the replacement ESM canister all the way into the drive module. Rotate the handle down to lock the ESM canister into place [Figure 20](#) shows how to insert an ESM canister.
- 7 Reconnect the SAS cable to the host.
- 8 Look at the lights on the ESM and disk drives to make sure that the new ESM is rebooting correctly. [Figure 26](#) shows the location of the lights on the ESM canister.
The lights should come on and go off intermittently for about 60 seconds (or possibly longer).

Figure 26 ESM Lights

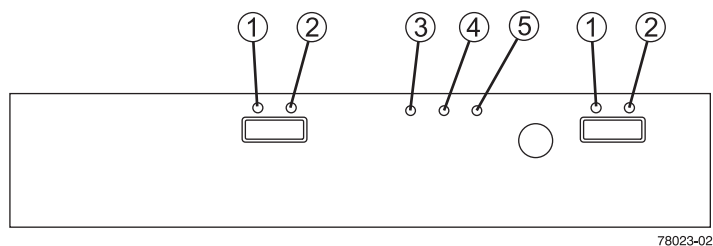

1. ESM Link Fault Light
2. ESM Link Light
3. ESM Service Light (Not Used)
4. ESM Fault Light
5. ESM Power Light

- 9 Look at the ESM Link light, ESM Link Fault light, Power light, and Fault light. Based on the light status, perform one of the following actions:
 - **All of the ESM Link lights and the Power light are on, and the ESM Link Fault lights and Fault light are off** – Go to step 11.
 - **All of the ESM Link lights are off or the Fault light is on** – Check whether the ESM canister has been installed correctly. Reinstall the ESM canister if necessary. Go to step 10.

10 Did this action correct the problem?

- **Yes** – Go to step 11.
- **No** – If the problem has not been fixed, contact a Customer and Technical Support representative.

11 Remove the antistatic protection.

Replacing a Failed Power-Fan Canister

This section describes how to replace a failed power-fan canister.

Before you begin to replace a power-fan canister in the drive module, gather antistatic protection and the replacement power-fan canister.

CAUTION **Possible hardware damage** – To prevent electrostatic discharge damage to the module, use proper antistatic protection when handling module components.

- 1 Put on antistatic protection.
- 2 Unpack the new power-fan canister.

Set the new power-fan canister on a dry, level surface near the drive module. Save all packing materials in case you need to return the power-fan canister.

- 3 Make sure that the power switch on the new power-fan canister is turned off. [Figure 27](#) shows the location of the power switch on a power-fan canister.

Figure 27 Fault Light and Power Switch on a Power-Fan Canister

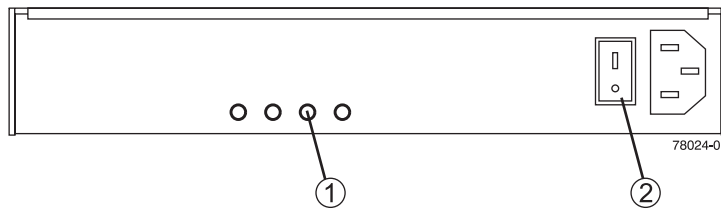

1. Fault Light
2. Power Switch

- 4 Check the Fault light to locate the failed power-fan canister. [Figure 27](#) shows the location of the Fault light. If a fault is detected, the amber Fault light will be on.
- 5 Turn off the power switch on both power-fan canisters in the drive module. [Figure 28](#) shows the location of the power switches on the power-fan canisters.

Figure 28 Power Switches on a Drive Module

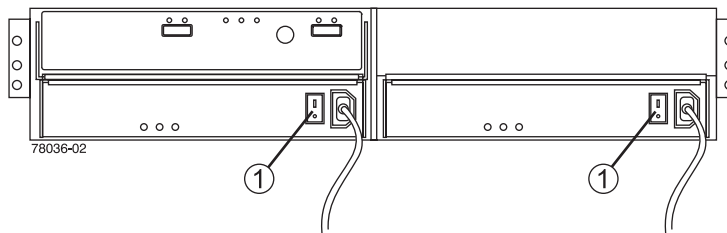

1. Power Switch



WARNING Risk of electrical shock – Never remove or install a power-fan canister that has its power cord plugged in and its power switch turned on. Doing so will expose you to the risk of electrical shock. Always turn off the power switch and unplug the power cord before you remove or install a power-fan canister.

- 6 Unplug the power cord from the failed power-fan canister.
- 7 Remove the power-fan canister from the drive module. [Figure 29](#) shows how to remove a power-fan canister.
 - a Rotate the latch down to disengage the power-fan canister.
 - b Use the latch as a handle to pull the power-fan canister out of the drive module.

Figure 29 Removing a Power-Fan Canister

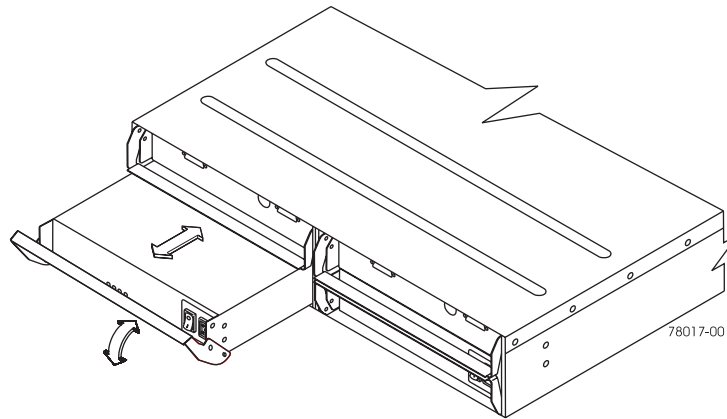

- 8 Slide the replacement power-fan canister all the way into the drive module. Rotate the handle up to lock the power-fan canister into place. [Figure 29](#) shows how to insert the power-fan canister.
- 9 Make sure that the power switch is turned off, and then plug in the power cord.
- 10 Turn on the power.
- 11 Check the Power light and Fault light on the new power-fan canister. [Figure 30 on page 32](#) shows the location of the Power light and Fault light on the power-fan canister.

Figure 30 Power Light and Fault Light on a Power-Fan Canister

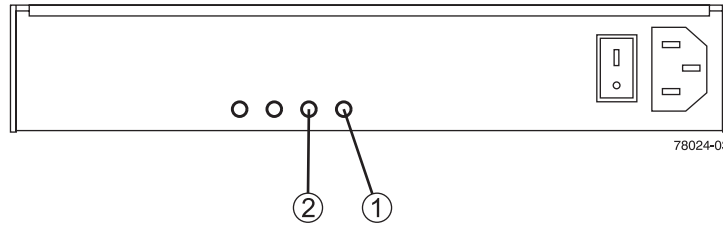

1. Power Light
2. Fault Light

12 Proceed to one of the following steps, based on the status of the Power light and Fault lights:

- **The Power light is on and the Fault light is off** – Go to step 14.
- **The Power light is off or the Fault light is on** – Verify that the power-fan canister is installed correctly. Reinstall the power-fan canister. Go to step 13.

13 Did this correct the problem?

- **Yes** – Go to step 14.
- **No** – If the problem has not been resolved, contact a Customer and Technical Support representative.

14 Remove the antistatic protection.

Replacing a Failed Disk Drive

This procedure describes how to replace a failed disk drive.

Before you begin to replace a disk drive in the drive module, gather antistatic protection and the replacement disk drive.

CAUTION **Possible loss of data access** – Never insert disk drives into an drive module without first confirming the disk drive firmware level is compatible. Inserting a disk drive with an incorrect firmware level can cause data loss or data corruption. For information about supported disk drive firmware levels, contact a Customer and Technical Support representative.

CAUTION **Possible loss of data access** – Magnetic fields will destroy all data on a disk drive and cause irreparable damage to the disk drive circuitry. To avoid loss of data access and damage to disk drives, always keep disk drives away from magnetic devices.

IMPORTANT Install only disk drives specifically designed for your drive module, and that have been tested and qualified by the factory.

CAUTION **Possible hardware damage** – To prevent electrostatic discharge damage to the drive module, use proper antistatic protection when handling components.

- 1** Put on antistatic protection.
- 2** Unpack the new disk drive.
Set the new disk drive on a dry, level surface near the drive module. Save all packing materials in case you need to return the disk drive.
- 3** Remove the failed disk drive from the drive module. [Figure 31](#) shows how to remove a disk drive.
 - a** Pull the drive handle to the left.
 - b** Use the handle to pull the disk drive out of the slot.
 - c** Put the disk drive on an antistatic, cushioned surface away from magnetic fields.

Figure 31 Removing a Disk Drive

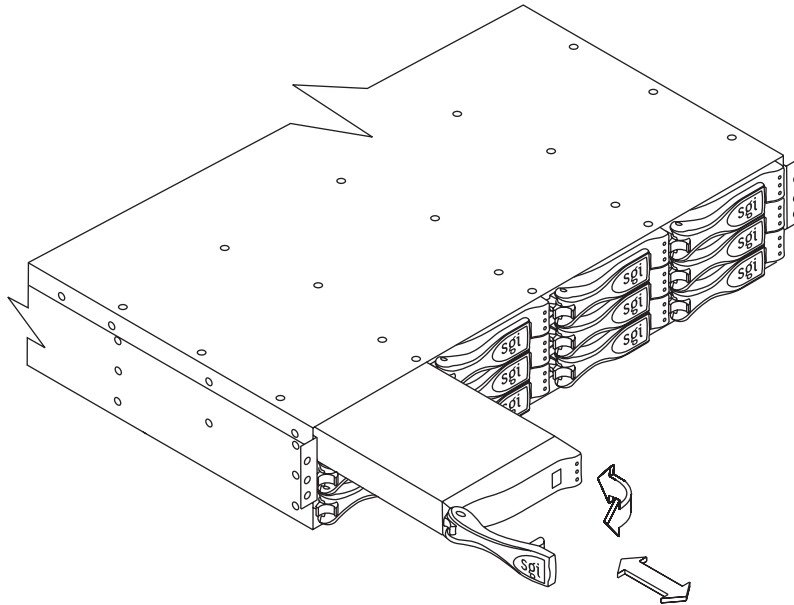

IMPORTANT If you accidentally remove an active disk drive, wait at least 30 seconds and then reinstall it. For the recovery procedure, refer to your storage management software.

- 4 Wait at least 30 seconds before you install the new disk drive.
 - a Place the disk drive on the slot guides, and slide the drive all the way into the slot.
 - b Push the drive handle to the right to lock the disk drive securely in place.
- 5 Choose one of the following options, based on the Active and Fault lights:
 - **The Active light is on** – Go to step 7.
 - **The Active light is off** – The disk drive might not be installed correctly. Remove the disk drive, wait 30 seconds, and then reinstall it. Go to step 6.

NOTE If the Active light flashes for longer than five minutes, the disk drive might be defective or the slot in the drive module might be defective.

- 6 Did this correct the problem?
 - **Yes** – Go to step 7.
 - **No** – If the problem has not been resolved, contact a Customer and Technical Support representative.
- 7 Remove the antistatic protection.